

## DEPARTMENT OF THE ARMY TECHNICAL MANUAL

DS AND GS MAINTENANCE MANUAL  
WATTMETER ME-82/U

Headquarters, Department of the Army, Washington, D. C. 20315  
20 November 1964

**WARNING**

Conform to all safety requirements applicable to the radio frequency (rf) transmitting equipment being measured or terminated when connecting or disconnecting the ME-82/U. Injury or DEATH could result from failure to comply with safe practices.

**Table of Contents**

		Paragraph	Page
<b>CHAPTER</b>	<b>1. INTRODUCTION</b>		
Section	I. General		
	Scope .....	1-1	3
	Index of publications.....	1-2	3
	Forms and records .....	1-3	3
	II. Description and data		
	Purpose and use .....	1-4	3
	Technical characteristics .....	1-5	3
	Description.....	1-6	4
<b>CHAPTER</b>	<b>2. UNPACKING AND CHECKING</b>		
	Unpacking.....	2-1	5
	Checking unpacked equipment .....	2-2	5
<b>CHAPTER</b>	<b>3. FUNCTIONING OF ME-82/U</b>		
	General.....	3-1	7
	Functioning .....	3-2	7
<b>CHAPTER</b>	<b>4. MAINTENANCE</b>		
	Test equipment required.....	4-1	10
	Tests.....	4-2	10
	Replacement of parts .....	4-3	10
<b>CHAPTER</b>	<b>5. GENERAL SUPPORT TESTING PROCEDURES</b>		
Section	I. Introduction		
	General.....	5-1	11
	Tools, test equipment, and additional equipment.....	5-2	11
	Modification work orders.....	5-3	11
	II. Tests		
	Physical tests and inspections.....	5-4	13
	Crystal diode, resistance, and meter sensitivity tests . . . . .	5-5	15
	Summary of test data .....	5-6	18
<b>APPENDIX.</b>	<b>REFERENCES .....</b>		<b>19</b>

\* This manual supersedes TB SIG 299, 4 October 1956.



Figure 1-1. Wattmeter ME-82/U.

## CHAPTER 1

### INTRODUCTION

---

#### Section I. GENERAL

##### 1-1. Scope

This manual covers direct and general support maintenance for Wattmeter ME-82/U (fig. 1-1). It includes instructions for troubleshooting, testing, and repairing of the ME82/U, and replacing maintenance parts. It also lists equipment, tools, and materials required in performing direct and general support maintenance. The maintenance allocation chart is in TM 11-5820-303-12P and the authorized repair parts lists are in TM 11-5820-303-12P and TM 11-5820-303-35P. Functioning of the ME-82/U is covered in chapter 3.

##### 1-2. Index of Publications

Refer to the latest issue of DA Pam 310-4 to determine whether there are new editions, changes, or additional publications pertaining to the equipment. Department of the Army Pamphlet 310-4 is a current index of technical manuals, technical bulletins, supply manuals (type 4, 6, 7, 8, and 9), supply bulletins, supply catalogs (type CL), lubrication orders, and modification work orders available through publications supply channels. The index lists the individual parts (-10, -20, -35, etc) and the latest changes to and revisions of each equipment publication.

##### 1-3. Forms and Records

*a. Reports of Maintenance and Unsatisfactory Equipment.* Use equipment forms and records in accordance with the instructions in TM 38-750.

*b. Report of Damaged or Improper Shipment.* Fill out and forward DD Form 6 (Report of Damaged or Improper Shipment) as prescribed in AR 700-58 (Army), NAVSANDA Publication 378 (Navy), and AFR 71-4 (Air Force).

*c. Reporting of Equipment Manual Improvements.* The direct reporting, by the individual user, of errors, omissions, and recommendations for improving this equipment manual is authorized and encouraged. DA Form 2028 will be used for reporting these improvements. This form may be completed by the use of pencil, pen, or typewriter. DA Form 2028 will be completed in triplicate and forwarded by the individual using the manual. The original and one copy will be forwarded direct to: Commanding General, U. S. Army Electronics Command, ATTN: AMSELMR-MA, Fort Monmouth, New Jersey, 07703. One information copy will be furnished to the individual's immediate supervisor (officer, noncommissioned officer, supervisor, etc).

#### Section II. DESCRIPTION AND DATA

---

##### 1-4. Purpose and Use

The ME-82/U provides power output indications of radio transmitters while acting as a dummy load. It is used when tuning and testing radio transmitters, and its

operating instructions are provided in the applicable radio transmitter technical manuals.

##### 1-5. Technical Characteristics

Frequency range	50 to 600 mc.
-----------------	---------------

Power range .....0 to 120 watts.  
 Input impedance .....52 ohms.  
 Type of meter .....200 microamperes dc, calibrated in watts, 120 watts full scale.  
 Accuracy .....± 5 percent.  
 Type of measurement.....Am, fm, or cw.  
 Voltage standing-wave ratio .....1.2 : 1 (maximum) when terminating 52-ohm coaxial cable.  
 Temperature range .....Up to 1500 F.  
 Heat dissipating facility .....52-ohm resistor in an air-cooled oil bath.

**1-6. Description**

The ME-82/U (fig. 1-1) is 6 inches wide, 7 1/2 inches high, and 13 5/8 inches long. The heat dissipating assembly consists of an oil bath and fins surrounding the dummy load resistor. A correction chart is provided on the top of the unit (fig. 1-2) for use when measuring frequencies between 50 and 200 megacycles (mc). The main components, including the two spare crystals can be reached from the bottom of the unit (fig. 3-1).

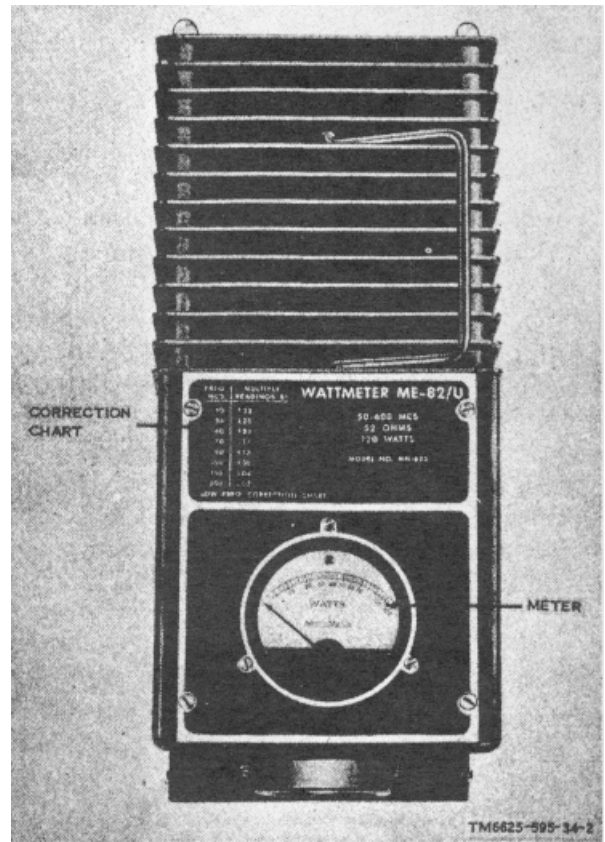

Figure 1-2. Wattmeter ME-82/U, top view.

## CHAPTER 2 UNPACKING AND CHECKING

---

### 2-1. Unpacking (fig. 2-1)

The ME-82/U is shipped fully assembled and ready for use. An exploded view of the packing materials is shown in figure 2-1. The packaged box is 93/4 inches high, 8 inches wide, 141/2 inches long, and weighs 17 pounds. When unpacking the ME82/U, perform the procedures listed (a through d) below.

#### Caution

**To avoid damage to the unit, do not thrust tools into the interior of the shipping container. Do not place the container where it is likely to fall.**

- a. Remove the gummed paper tape that seals the top of the corrugated carton.
- b. Remove the corrugated protector and cushioning material.
- c. Remove the moisture-vaporproof barrier package from the shipping container.

- d. Remove the moisture-vaporproof barrier from the ME-82/U.

### 2-2. Checking Unpacked Equipment

- a. Check the equipment for damage incurred during shipment. Inspect the ends of the unit for coolant leakage. If the equipment has been damaged, report the damage on DD Form 6 (para 1-3).
- b. Check the equipment for completeness as listed on the packing list. Report all discrepancies (para 1-3).
- c. If the equipment has been used or reconditioned, see whether it has been changed by a modification work order (MWO). If the equipment has been modified, the MWO number will appear near the designation plate.

#### Note

**Current MWO's applicable to the equipment are listed in DA Pam 310-4.**

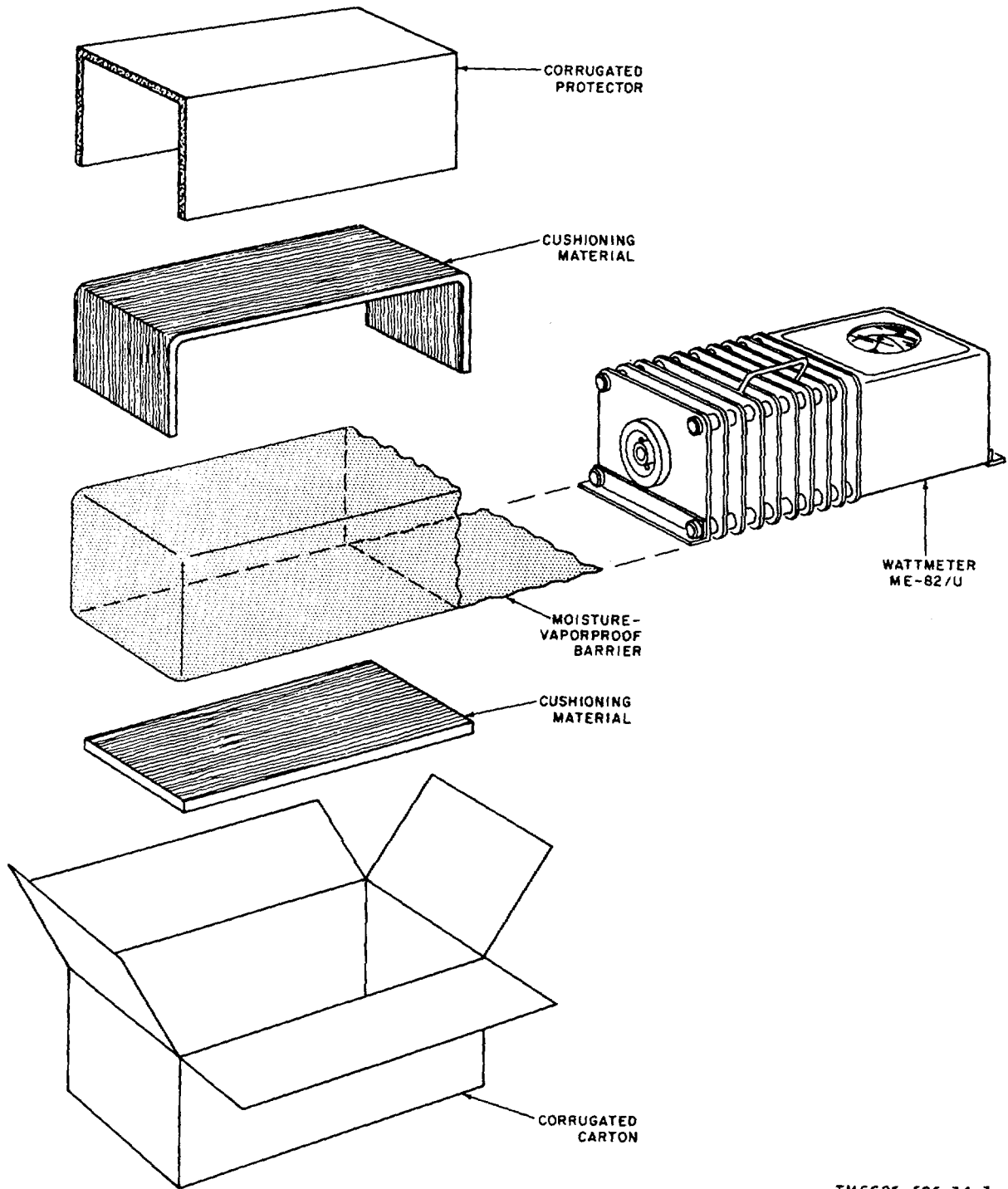

TM 6625-595-34-3

Figure 2-1. Wattmeter ME-821U, packaging diagram.

## CHAPTER 3 FUNCTIONING OF ME-82/U

---

### 3-1. General (fig. 3-1)

The ME-82/U consists of two assemblies: the dummy load assembly, and the measuring circuit assembly. The dummy load assembly consists of a coupler and a dummy load. The measuring circuit utilizes a portion of the coupler and conventional circuits for measuring direct current (dc).

### 3-2. Functioning

Radiofrequency (rf) input is applied through the input connector, which is physically mounted on the coupler. The rf input is applied through the transmission line of the coupler to the dummy load for dissipation. A piece of wire (L) is positioned adjacent to the transmission line. Coupling between the wire and the transmission line is represented by capacitor C1. Crystal diode CR1 rectifies the rf signal and causes direct current flow through resistor R2, the meter, resistor R1, and inductor L1. Capacitor C2 represents coupling from the wire to the shield of the coupler. The direct current flow through the meter is proportional to the amount of rf signal and indicated as the amount of power dissipated in the dummy load.

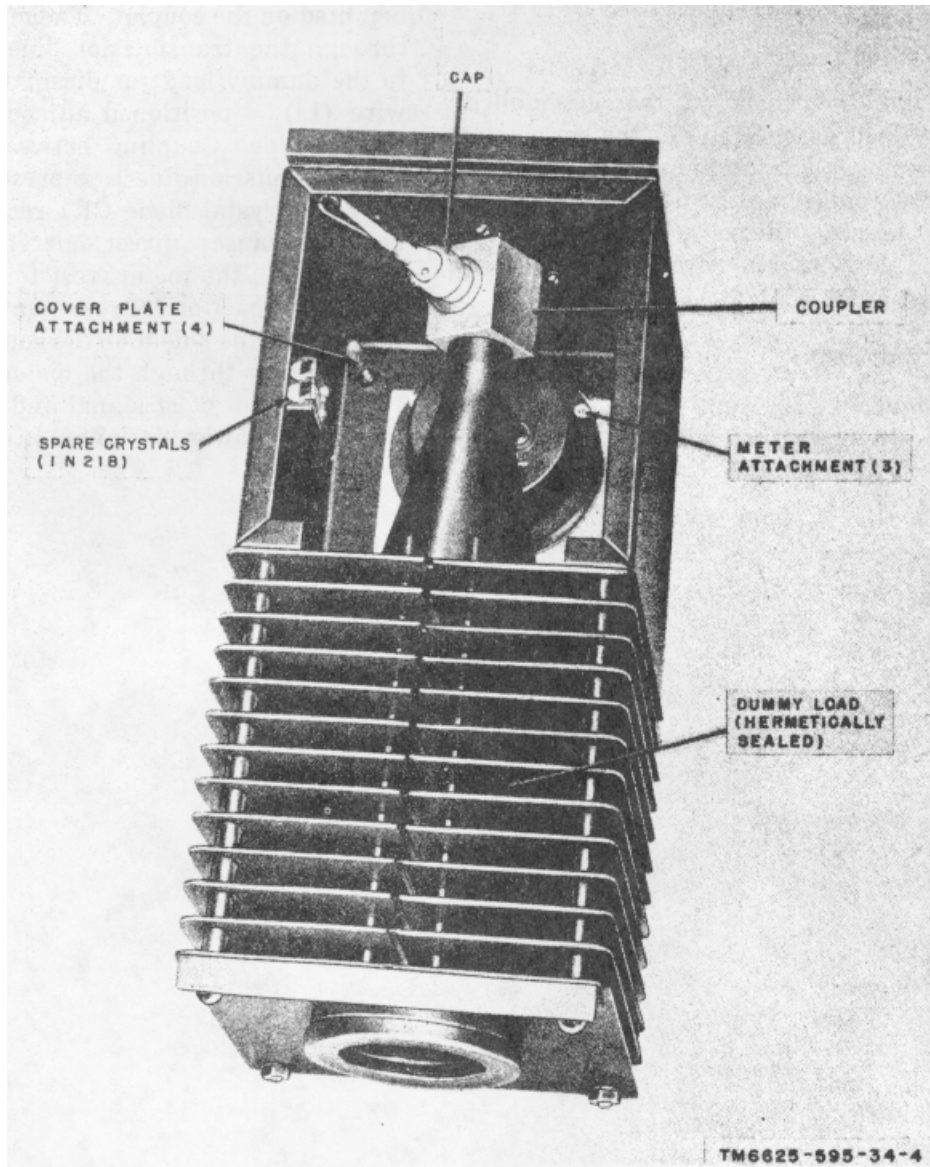

Figure 3-1. Wattmeter ME-82/U, bottom A.



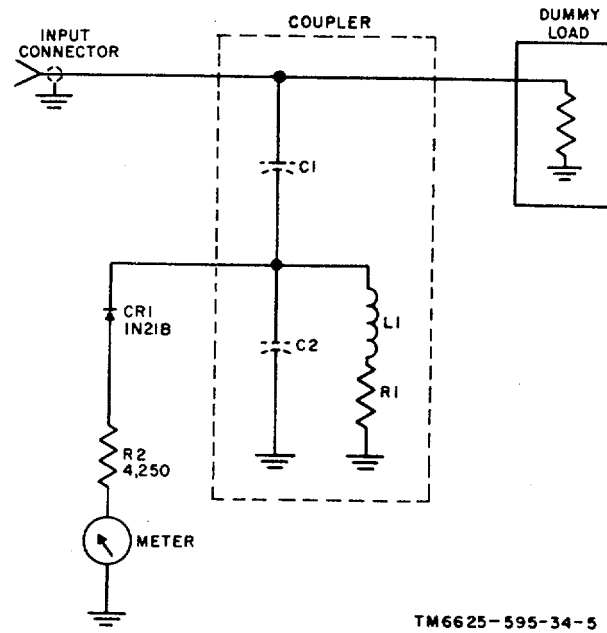

Figure 3-2. Wattmeter ME-8,U, Schematic diagram.

## CHAPTER 4

### MAINTENANCE

---

#### 4-1. Test Equipment Required

- a. Multimeter TS-352/U, TS-352A/U, or TS-352B/U.
- b. Crystal Rectifier Test Set TS-28, , TS268B/U, TS-268C.'U, TS--268D/U, or TS268E/U.

#### 4-2. Tests

a. **Crystal Diode Tests.** The crystal diode is tested by use of TS-268(\*)/U or an equivalent substitute. Instructions for using the TS268(\*)/U are contained inside the cover of the test set.

b. **Dummy Load Resistance Measurement.** Prepare the TS-352(\*)/U to measure resistance with the range switch operated to RX1. Connect one test lead to the center connector of the input connector of the ME-82/U and the other test lead to chassis ground. The TS352(\*)/U shall indicate approximately 52 ohms.

#### 4-3. Replacement of Parts

a. **Replacement of Crystal Diode.** Replacement of the crystal diode is performed as indicated in (1) through (5) below.

(1) Unscrew the cap connected to the coupler connector (fig. 3-1).

(2) Lift the crystal diode from the socket in the coupler.

(3) Remove a spare crystal diode from the spare crystal diode holder.

(4) Hold the spare crystal diode by its body and touch one finger of the hand holding the crystal diode to ground of the coupler to discharge any electrostatic charge that may be present.

(5) Insert the crystal diode into the socket of the coupler and replace the cap on the coupler connector.

b. **Replacement of Meter Assembly.** Replacement of the meter assembly is performed as indicated in (1) through (7) below.

(1) Remove the cap from the coupler connector.

(2) Remove the plastic clamp that secures the wire to the rear of the front panel.

(3) Remove the four screws that secure the cover plate to the top of the cabinet.

(4) Remove the cover plate with the meter assembly attached (5) Remove the conductors connected to the meter terminals.

(6) Remove the three screws that secure the meter assembly to the cover plate and remove the meter.

(7) Replace the meter by reassembling the parts in reverse sequence to the order of disassembly.

## CHAPTER 5 GENERAL SUPPORT TESTING PROCEDURES

### Section I. INTRODUCTION

#### 5-1. General

*a.* Testing procedures are prepared for use by Signal Field Maintenance Shops and Service Organizations responsible for general support maintenance of electronic equipment to determine the acceptability of repaired equipment. These procedures set forth specific requirements that repaired electronic equipment must meet before it is returned to the using organization. Perform the physical tests and inspections as outlined in paragraph 5-4 before proceeding to the test in paragraph 5-5. A summary of the performance standards is given in paragraph 5-6.

*b.* Each test depends on the preceding one for certain operating procedures and, where applicable, for test set calibrations. Comply with the instructions preceding each chart before proceeding to the chart. Perform each test in sequence. Do not vary the sequence. For each step, perform all the actions required in the Control settings column, and then perform each specific test procedure and verify it against its performance standard.

#### 5-2. Tools, Test Equipment, and Additional Equipment

All tools (*a* below), test equipment (*b* below), and additional equipment (*c* below) required to perform the testing procedures in this chapter are authorized under TA 11-17, Signal Field Maintenance Shops; TA 11-100 (11-17), Allowance of Signal Corps Expendable Supplies for Signal Field Maintenance Shops, TOE 11-158D, Signal Depot Company; and TA 11-101 (11-158), Allowance of Signal Corps Expendable Supplies for Signal Depot Company, or are repair part items of the subject equipment authorized for stockage at general support maintenance level. If these procedures are performed with other types of test equipment, an allowance must be made for any test connection or test result that may differ from those given in these procedures.

*a. Tools.* Tools required are contained in Tool Kit, Radar and Radio Repairman TK87/U.

#### *b. Test Equipment.*

Nomenclature	Federal stock No.	Reference
Crystal Rectifier Test Set TS-268(*)/U <sup>a</sup>	6625-188-5851	TM 11-1242
Meter Test Equipment AN/GSM-1(*) <sup>b</sup>	6625-669-0747	TM 11-2535A
Meter Test Set TS-682(*)/GSM-1 <sup>c</sup>	6625-570-5722	TM 11-2019
Test Set I-49(*) <sup>d</sup>	6695-537-4470	TM 11-5540
Light Assembly, Electric MX-1292/PAQ		

<sup>a</sup> Crystal Rectifier Test Set TS-268/U, TS-268B/U, TS-268C/U, TS-26i8D/U, or TS-268E/U.

<sup>b</sup> Meter Test Equipment AN/GSM-IB or AN/GSM-IC.

<sup>c</sup> Meter Test Set TS-682/GSM- I and TS-682A/GSM-I.

<sup>d</sup> Test Set 1-49, I-49A, or 1-49B.

#### *c. Additional Equipment.*

Nomenclature	Federal stock No.	Reference
Power Supply PP-1097(*)/G <sup>a</sup>	6130-669-6640	TM 11-5111
Battery BA-30/U, 3 each	6135-120-1020	

<sup>a</sup> Power Supply PP-1097A/G or PP-1097B/G.

#### 5-3. Modification Work Orders

The tests listed in paragraph 5-5 assume that no modification work orders (MWO's) have been performed. If an MWO has been performed, allowances must be made for any change in test connections and performance standards. A current listing of MWO's will be found in DA Pamphlet 310-4.

Section II. TESTS

5-4. Physical Tests and Inspections

- a. *Test Equipment and Materials.* Light Assembly, Electric MX-1292/PAQ.
- b. *Test Connections and Conditions.*
  - (1) Do not make any connections to the equipment.
  - (2) Perform the following checks after repairs are completed, prior to reassembly of the equipment.
- c. *Test Procedure.*

Step No.	Control Settings		Test Procedure	Performance Standard
	Test Equipment	Equipment under Test		
1	NIA	N/A	<ul style="list-style-type: none"> <li>a. Inspect case, cooling fins, and connectors for looseness, missing parts, and damage. be securely mounted.</li> <li>b. Inspect meter for legibility and evidence of damage.  <i>Caution:</i> Before inserting the crystal diode into the socket, hold the crystal diode by its body and touch one linger of the hand holding the crystal diode to the ground section of the socket to discharge any electrostatic charge that may be present.</li> <li>c. Remove crystal CR1 from resistor-coupler assembly and spare crystals from holder. Inspect for damage and correct number and type.</li> <li>d. Inspect the cable for condition of insulation. cracks and fraying.</li> <li>e. Inspect metal surfaces for condition of finish. bare metal. <i>Note:</i> Touchup painting is recommended in lieu of refinishing whenever practicable.</li> <li>f. Check equipment for applicable MWO's and note any MWO's not performed. (See DA Pam 310-4 for a list of MWO's.)</li> </ul>	<ul style="list-style-type: none"> <li>a. There should be no evidence of damage, or loose or missing parts. All connectors should</li> <li>b. Meter scale should be legible. Glass should be intact and meter should show no evidence of damage.</li> <li>c. Crystals should show no evidence of damage. Crystal type should be 1N21B. There should be 2 spare crystals.</li> <li>d. Insulation should be free from</li> <li>e. All metal surfaces intended to be painted should not show</li> <li>f. If MWO is performed, MWO number appears on equipment.</li> </ul>
2	MX-1292/PAQ 245V FOR M. V. Lamp: ON	N/A	<ul style="list-style-type: none"> <li>a. Expose chassis to direct rays of MX-1292/PAQ and inspect condition of moisture and fungiproofing (MFP) varnish.  <b>Note: MFP varnish appears blue-green when exposed to rays of the MX-1292/PAQ.</b></li> <li>b. Turn off the MX-1292/PAQ.</li> </ul>	<ul style="list-style-type: none"> <li>a. Meter terminal connections and all bare metal (except connector contacts and spare crystals) should be completely covered with MFP varnish. <i>Note:</i> Do not apply varnish to parts that were not originally finished with MFP varnish.</li> <li>b. None.</li> </ul>

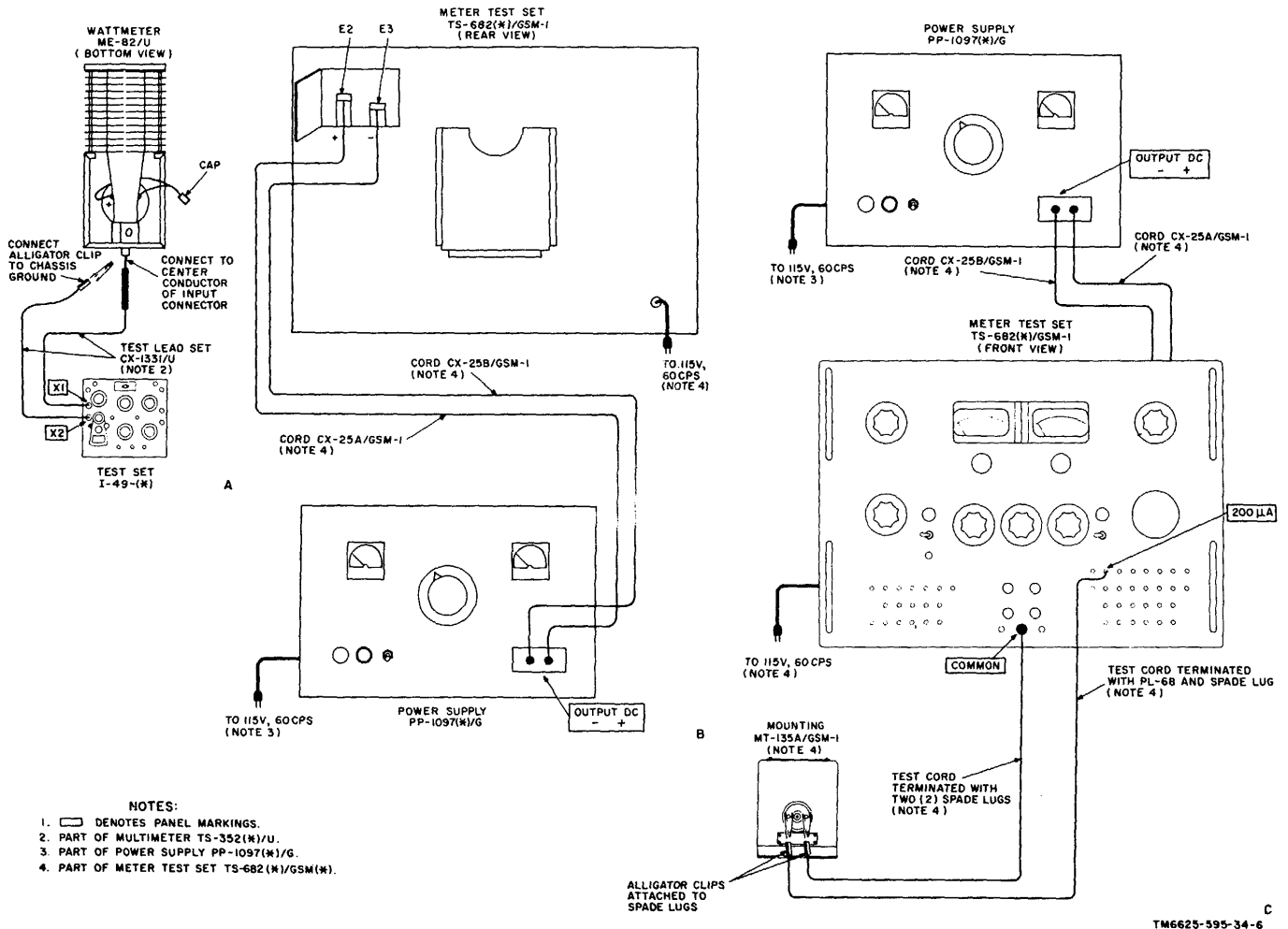

TM6625-595-34-6 C

Figure 5-1. General support test setup for crystal, resistance, and meter sensitivity tests.

**5-5. Crystal Diode, Resistance, and Meter Sensitivity Tests**

*a. Test Equipment and Materials.*

- (1) Crystal Rectifier Test Set TS-268(\*)/U.
- (2) Meter Test Set TS-682/GSM-1 or TS-682A/GSM-1 (p/o AN/GSM-1B or AN/GSM1C).
- (3) Test Set I-49(\*) (p/o AN/GSM-1B).
- (4) Power Supply PP-1097(\*)/G.
- (5) Test cord terminated with spade lug on each end (p/o AN/GSM-1B).
- (6) Test cord terminated with spade lug and PL68 (p/o AN/GSM-1B).
- (7) Alligator clip, screw terminal, 2 each (p/o AN/GSM-1B).
- (8) Cord CX-25A/GSM-1 (p/o AN/GSM-1B).
- (9) Cord CX-25B/GSM-1B (p/o AN/GSM-1B).
- (10) Test Lead Set CX-1331(\*)/U (p/o TS-352/U).
- (11) Batteries BA-30/U, 3 each.

*b. Test Connections and Conditions. None.*

*c. Test Procedure.*

Step No.	Control Settings		Test Procedure	Performance Standard
	Test Equipment	Equipment under Test		
1	TS-268(*)/U	N/A	<p>CRYSTAL DIODE TESTS</p> <p>a. Operate ADJUST METER control for full scale deflection on meter (O ohm) of TS-268(*) /U.</p> <p><b>Note: On TS-268D/U, the PUSH TO OPERATE switch must be depressed to obtain meter indication.</b></p> <p>b. Operate meter selector switch to ADJ. METER (right position) and vary ADJ. METER control until meter pointer indicates full scale (O ohm) position.</p> <p><b>Caution: Before inserting crystal into crystal holder, hold crystal by its body, and touch one finger of hand (which is holding crystal) to ground section of crystal holder to discharge any electrostatic charge that may be present.</b></p> <p>c. Insert crystal diode into crystal holder of TS-268(*)/U.</p> <p>d. Repeat the procedure given in a above.</p> <p>e. Operate selector switch to FWD RES (TS-268/U) or FRONT RES (TS-268B/U, TS-268C/U, and TS-268D/U) and read forward resistance of crystal in kilohms on upper scale of meter.</p>	<p>a. None.</p> <p>b. None.</p> <p>c. None.</p> <p>d. None.</p> <p>e. Forward resistance should not be greater than 0.5 kilohm (500 ohms).</p>

Step No.	Control Settings		Test Procedure	Performance Standard
	Test Equipment	Equipment under Test		
			<p>f. Operate selector switch to BACK RES and read reverse resistance of crystal in kilohms on upper scale of meter.</p> <p>g. Repeat procedures in b above.</p> <p>h. Operate selector switch to BACK CURRENT and read current indication on MA scale of meter.</p> <p>i. Remove crystal diode and replace it in ME-82/U.</p> <p>j. Repeat the procedures in a through i above for both spare crystal diodes in the ME-82/U.</p> <p>k. Turn off the TS-268(*)/U in the following manner:            TS-268/U: Operate selector switch to OFF.            TS-268B/U and TS-268 C/U: Operate ADJUST METER control completely counterclockwise.            TS-268D/U: Release PUSH TO OPERATE switch.</p>	<p>f. Ratio of reverse resistance to forward resistance (e above) should be greater than 10 to 1.</p> <p>g. None.</p> <p>h. Meter pointer should indicate out of the POOR (green) area of the colored scale.</p> <p>i. None.</p> <p>j. Same as a through i above.</p> <p>k. None.</p>
2	<p>I-49(*)            Pointer lock: operated toward galvanometer            BA switch: INT            GA switch: RVM            RES-VAR-MUR dial: RES            MULTIPLY BY dial: 1/1            Units decade dial: 0            Itens decade dial: 5            Hundreds decade dial: 0            Thousands decade dial: 0</p>	N/A	<p>DUMMY LOAD RESISTANCE TEST</p> <p>a. Install three batteries BA-30/U in the I-49(*).</p> <p>b. Position galvanometer pointer by loosening galvanometer screw and adjusting the zeroing knob.</p> <p><b>Note: The 1-49(*) must be placed on a level surface to obtain accurate readings.</b></p> <p>c. Connect a jumper between line binding posts X1 and X2. Depress GA SENS .01 switch momentarily. If pointer deflects to the left (-) and returns to center, the I-49(*) is ready for use. If pointer deflects to right (+), reverse polarity of batteries. If pointer does not deflect, test set is faulty and should be replaced.</p> <p>d. Remove jumper from binding posts X1 and X2 and connect equipment as shown in A, figure 5-1.</p>	<p>a. None.</p> <p>b. None.</p> <p>c. None.</p> <p>d. None.</p>

Step No.	Control Settings		Test Procedure	Performance Standard
	Test Equipment	Equipment under Test		
			<p>e. Operate MULTIPLY BY dial to 1/100 and thousands decade dial to 5, hundreds decade dial to 2, and tens decade dial to 0.</p> <p>f. Depress GA SENS .01 switch and note direction of movement of pointer. If movement was to right, increase resistance of decade dials until pointer does not move from 0 with GA SENS .01 switch depressed. If pointer moves to left, decrease resistance total on decade dials. Repeat above procedure, using GA SENS .1 and the GA SENS 1 switches.</p> <p>g. Operate INT-EXT-BA switch to EXT and pointer lock to locked position. Disconnect test setup and remove batteries from I-49(*).</p>	<p>e. None.</p> <p>f. 1-49(*) galvanometer is balanced at 52 ohms ± 2.</p> <p>g. None.</p>
3	<p>PP-1097(*)/G POWER: OFF</p> <p>OUTPUT VOLTAGE</p> <p>ADJUST: completely counterclockwise TS-82(*) / GSM-1</p> <p>AC LINE ON-OFF: OFF BATTERY: OFF</p> <p>ALT CURRENT AC VOLTS DC VOLTS FINE CONTROL: completely counterclockwise</p> <p>ALT CURRENT AC VOLTS DC VOLTS COURSE CONTROL: completely counterclockwise</p>	N/A	<p>METER SENSITIVITY TESTS</p> <p>a. Remove crystal diode and meter from ME-82/U and mount meter on mounting MT-135 A/GSM-1.</p> <p>b. Connect equipment as shown in B and C of figure 5-1.</p> <p>c. Operate POWER switch on PP-1097(*)/G to ON and allow a 5-minute warmup period.</p> <p>d. Slowly operate OUTPUT VOLTAGE ADJUST control for 12 volts indication of DC VOLTS meter of PP-1097 (*) /G.</p> <p>e. Adjust DC METER (TS-682/GSM-1) or DC MICRO-AMPERES (TS-682A/GSM-1) meter to zero by means of zero adjusting control located below the meter.</p> <p><i>Note:</i> To overcome internal friction of meter, tap meter face (TS682/GSM-1) lightly with fingers or operate BUZZER switch (TS-682A/GSM-1) while zeroing meter.</p>	<p>a. None.</p> <p>b. None.</p> <p>c. None.</p> <p>d. None.</p> <p>e. None.</p>



Step No.	Control Settings		Test Procedure	Performance Standard
	Test Equipment	Equipment under Test		
	<p>DIRECT CURRENT FINE CONTROL: completely counterclockwise</p> <p>DIRECT CURRENT COARSE CONTROL completely counterclockwise</p> <p>Right-hand selector switch (DIRECT CURRENT SELECTOR on TS682A/GSM-1) 100 UA to 400 UA</p> <p>Center selector switch: AC &amp; DC CUR (TS-682/GSM-1) or DC MA &amp; UA (TS-682A/GSM-1)</p> <p>Left-hand selector switch: any position (TS-682/GMS-1) or ALL OTHER AC &amp; DC SCALES (TS82A I/ GSM-1)</p>		<p>f. Operate BATTERY switch on TS-682(*)/GSM-1 to ON.</p> <p>g. Slowly operate TS-682(*)/GSM-1 DIRECT CURRENT COARSE CONTROL clockwise until ME-82/U WATTS meter indicates 100.</p> <p>h. Slowly operate TS-682(*)/GSM-1 DIRECT CURRENT FINE CONTROL clockwise until ME-82/U indicates exactly 120.</p> <p>i. Note indication on DC METER (TS-682/GSM-1) or DC MICROAMPERES (TS-682 A/GSM-1) meter.</p> <p>j. Operate TS-682(*)/GSM-1 DIRECT CURRENT COARSE CONTROL and DIRECT CURRENT FINE CONTROL completely counterclockwise.</p> <p>k. Operate TS-682(*)/GSM-1 BATTERY switch and AC LINE switch to OFF.</p> <p>l. Operate PP-1097(*)/G POWER 1. switch to OFF.</p> <p>m. Disconnect test setup and replace crystal diode CRI in ME-82/U.</p>	<p>f. None.</p> <p>g. None.</p> <p>h. None.</p> <p>i. WATTS meter on ME-82/U indicates 120 and TS-682(*)/GSM-1 meter should indicate 200 microamperes <math>\pm 4</math>.</p> <p>k. None.</p>

### 5-6. Summary of Test Data

Personnel may find it convenient to arrange a checklist in a manner similar to that shown below.

Test No.	Description	Performance standard	Test data
	Crystal Diode Tests		
1e	Forward resistance	Forward resistance should not be greater than 0.5 kilohm (500 ohms).	-----
1f	Ratio of reverse to forward resistance.	Ratio of reverse to forward resistance should be greater than 10 to 1.	-----
1h	Reverse current	Meter pointer should indicate out of POOR (green) area of colored scale.	-----
1j	Spare crystal diodes forward and reverse resistance, and reverse current tests.	Same as 1e, 1f, and 1h above.	-----
2t	Dummy load resistance test	I-49(*) galvanometer is balanced at 62 ohms $\pm 2$ .	-----
8h	WATTS meter sensitivity test	WATTS meter on ME-82/U indicates 120 and TS-82(*)/GSM-1 meter indicates 200 microamperes $\pm 4$ .	-----

**APPENDIX  
REFERENCES**

Following is a list of references available to the repairman of the ME-82/U.

DA Pam 310-4	Index of Technical Manuals, Technical Bulletins, Supply Manuals (Types 4, 6, 7, 8, and 9), Supply Catalogs (type CL), Supply Bulletins, Lubrication Orders, and Modification Work Orders.	TM 11-2535A	49B and Resistance Bridges ZM-4A/U and ZM-4B/U. Meter Test Equipments AN/GSM-1B and AN/GSM-1C.
DA Pam 310-21	Military Publications: Index of Supply Manuals; Signal Corps.	TM 11-5111	Power Supplies PP-1097A/G and PP-1097B/G. Multimeter TS-297/U. Electric Light Assembly MX-1292/PAQ.
SB 11-526	Conversion of Tool Equipment TE-113 to Tool Kits TK-87( )/U and TKS88 ( )/U.	TM 11-5500 TM 11-5540	Operator's and Organizational Maintenance Repair Parts and Special Tools List and Maintenance Allocation Chart Power Accessories Group OA-1676/GRC.
TM 11-1242	Crystal Rectifier Test Sets TS-268/U, TS-268A/U, TS-268B/U, TS-268C/U, TS-268D/U, and TS-268E/U.	TM 11-5820-303-12P	Field and Depot Maintenance Repair Parts and Special Tools List Power Accessories Group OA-1676/GRC.
TM 11-2019	Test Set I-49, I-49A, and I-	TM 11-820-303-35p	Army Equipment Record Procedures.
		TM 38-750	

By Order of the Secretary of the Army:

**HAROLD K. JOHNSON,**  
*General, United States Army*  
*Chief of Staff*

Official:

**J. C. LAMBERT,**  
*Brigadier General, United States Army*  
*The Adjutant General*

Distribution:

Active Army:

USASA (2)  
 CNGB (1)  
 OCC-E (7)  
 CofT (1)  
 CofEngrs (1)  
 TSG (1)  
 CofSptS (1)  
 USAMC (5)  
 USCONARC (5)  
 ARADCOM (2)  
 ARADCOM Rgn (2)  
 OS Maj Comd (3)  
 LOGCOMD (2)  
 USAECOM (7)  
 USAMICOM (4)  
 USASMC (2)  
 USASCC (4)  
 USACDCCEA (1)  
 USACDCCEA, Ft  
     Monmouth (1)  
 USAAVCOM (1)  
 MDW (1)  
 Armies (2)  
 Corps (2)  
 USAC (3)  
 11th Air Assault  
     Div (3)  
 USATC AD (2)  
 USATC Inf (2)  
 USATC Armor (2)  
 USATC Engr (2)  
 USASTC (3)  
 Svc Colleges (2)  
 Br Svc Sch (2) except  
     USASESCS (40)  
 Army Dep (2) except  
     SAAD (30) LXAD, TOAD (14)  
     FTWOAD (10) LEAD, NAAD,  
     SVAD (5) SHAD, CHAD (3)

ATAD (4)  
 GENDEP (OS) (2)  
 Sig Sec, GENDEP(OS) (5)  
 Sig Dep (12)  
 Instl (2) except Ft Monmouth (63)  
     Ft Hancock (4) Ft Gordon (5)  
     Ft Huachuca (10)  
 Army Tml (1) except Oakland (5)  
 POE (1)  
 Sig Fid Maint Shops (2)  
 WRAMC (1)  
 US Army Pictorial Cen (2)  
 Chicago Proc Dist (1)  
 AMS (1)  
 USAERDAA (2)  
 USAERDAW (13)  
 USACDCOA (1)  
 USACDCQMA (1)  
 USACDCTA (1)  
 USACDCADA (1)  
 USACDCARMA (1)  
 USACDCAVNA (2)  
 USACDCARTYA (1)  
 USACDCSWA (1)  
 USACDCEC (5)  
 Natick Army Lab (5)  
 Units org under fol TOE: (2 ea UNOINDC)  
 1-17  
 11-16  
 11-57  
 11-97  
 11-98  
 11-117  
 11-155  
 11-157  
 11-500 AA-AE (4)  
 11-557  
 11-587  
 11-592  
 11-597

NG: State AG (3) Units same as active Army except allowance is one copy each unit.

USAR: None.

For explanation of abbreviations used, see AR 820-50.

\*U.S. GOVERNMENT PRINTING OFFICE : 1987 0 - 201-421 (71237)



